

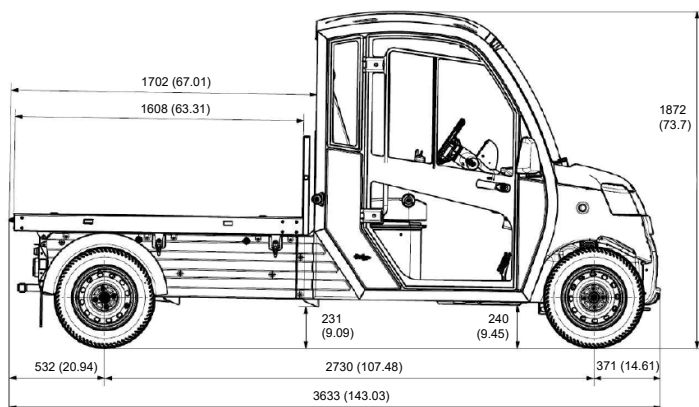

## DIMENSIONS

### L (Long chassis)



### S (Short chassis)

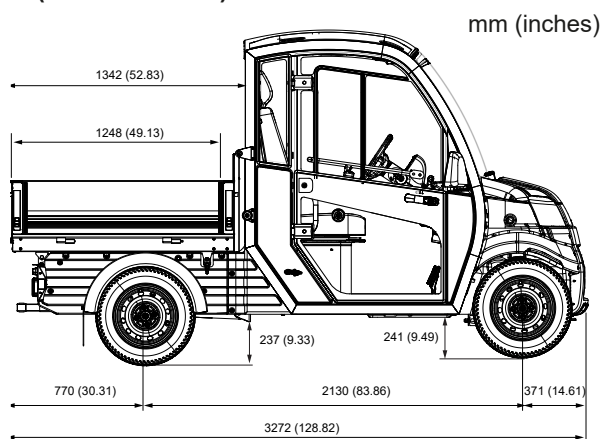

Specifications:	L (Long wheel base)	S (Short wheel base)
Motor 48V	High efficient 3-phase AC engine	
Output rating	8 kW (10,7 Hp)	
Peak power	14,3 kW (19,2 Hp)	
Motor controller	Curtis 350 A	
Battery	Lead Acid 8x6V or Lithium	
Battery capacity (lithium)	6,1 - 21,4 kWh	
Chassis	Hot dip galvanized steel frame	
Brakes	Discs front, drums rear	
Tires	165/70 R13	
Outer turning radius	4250 mm (13.94 feet)	3400 mm (11.15 feet)
Mass in running order*	495 kg (1091 lbs)	491 kg (1082 lbs)
Technically permissible laden mass	1850 kg (4079 lbs)	1350 kg (2976 lbs)
<b>Performance</b>		
Top speed	30 Km/h (19 mph)	
Range (WLTP - combined range)	Up to 200 Km (124 miles)	
Operating grade	< 20%	

\* Battery weight not included

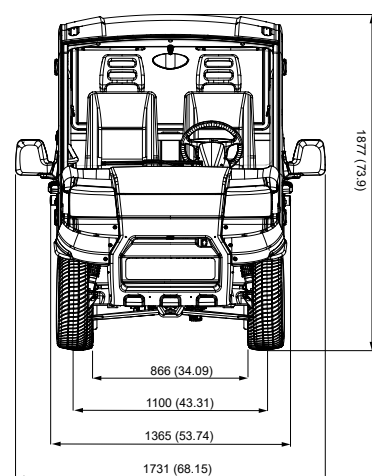

# URBAN XR